

Ultra-Low Quiescent (ULQ™) Dual Synchronous Step-Down Controller with 5V and 3.3V LDOs

Check for Samples: [TPS51285A](#), [TPS51285B](#)

FEATURES

- Input Voltage Range: 5 V to 24 V
- Output Voltages: 5 V and 3.3 V (Adjustable Range $\pm 10\%$)
- Built-in, 100-mA, 5-V and 3.3-V LDOs
- Clock Output for Charge-Pump
- $\pm 1\%$ Reference Accuracy
- Adaptive On-Time D-CAP™ Mode Control Architecture with 400 kHz (CH1) and 475 kHz (CH2) Frequency
- Auto-skip and ULQ™ modes for long battery life in system stand-by mode
- Internal 0.8-ms Voltage Servo Soft-Start
- Low-Side $R_{DS(on)}$ Current Sensing Scheme
- Built-In Output Discharge Function
- Separate Enable Input for Switchers
- Dedicated OC Setting Terminals
- Power Good Indicator
- OVP, UVP and OCP Protection
- Non-Latch UVLO and OTP Protection
- 20-Pin, 3 mm x 3 mm, QFN (RUK)

APPLICATIONS

- Notebook Computers
- Tablet Computers

DESCRIPTION

The TPS51285A and TPS51285B are cost-effective, dual synchronous buck controllers with 5-V and 3.3-V LDOs, targeted for notebook system-power supply solutions. The device achieves low power consumption by the use of auto-skip and ULQ™ modes, which is beneficial for long battery life in system stand-by mode. The 256-kHz VCLK output is provided to drive an external charge pump, generating gate drive voltage for the load switches with minimum power consumption in the main converter. The device employs adaptive on-time D-CAP™ mode control which enables fast load transient response without external compensation network. The TPS51285A/B operates with supply input voltage ranging from 5V to 24V and supports output voltages of 5 V and 3.3 V. The TPS51285A and TPS51285B are available in a 20-pin 3 x 3 (mm) QFN package and is specified from -40°C to 85°C.

ORDERING INFORMATION⁽¹⁾

ORDERABLE DEVICE NUMBER	ALWAYS On-LDO	OUTPUT SUPPLY	QUANTITY
TPS51285ARUKR	VREG3	Tape and Reel	3000
TPS51285ARUKT		Mini reel	250
TPS51285BRUKR	VREG3 and VREG5	Tape and Reel	3000
TPS51285BRUKT		Mini reel	250

(1) For the most current package and ordering information see the Package Option Addendum at the end of this document, or see the TI website at www.ti.com.



Please be aware that an important notice concerning availability, standard warranty, and use in critical applications of Texas Instruments semiconductor products and disclaimers thereto appears at the end of this data sheet.

D-CAP, ULQ are trademarks of Texas Instruments.

PRODUCTION DATA information is current as of publication date. Products conform to specifications per the terms of the Texas Instruments standard warranty. Production processing does not necessarily include testing of all parameters.

Copyright © 2013, Texas Instruments Incorporated



These devices have limited built-in ESD protection. The leads should be shorted together or the device placed in conductive foam during storage or handling to prevent electrostatic damage to the MOS gates.

TYPICAL APPLICATION DIAGRAMS

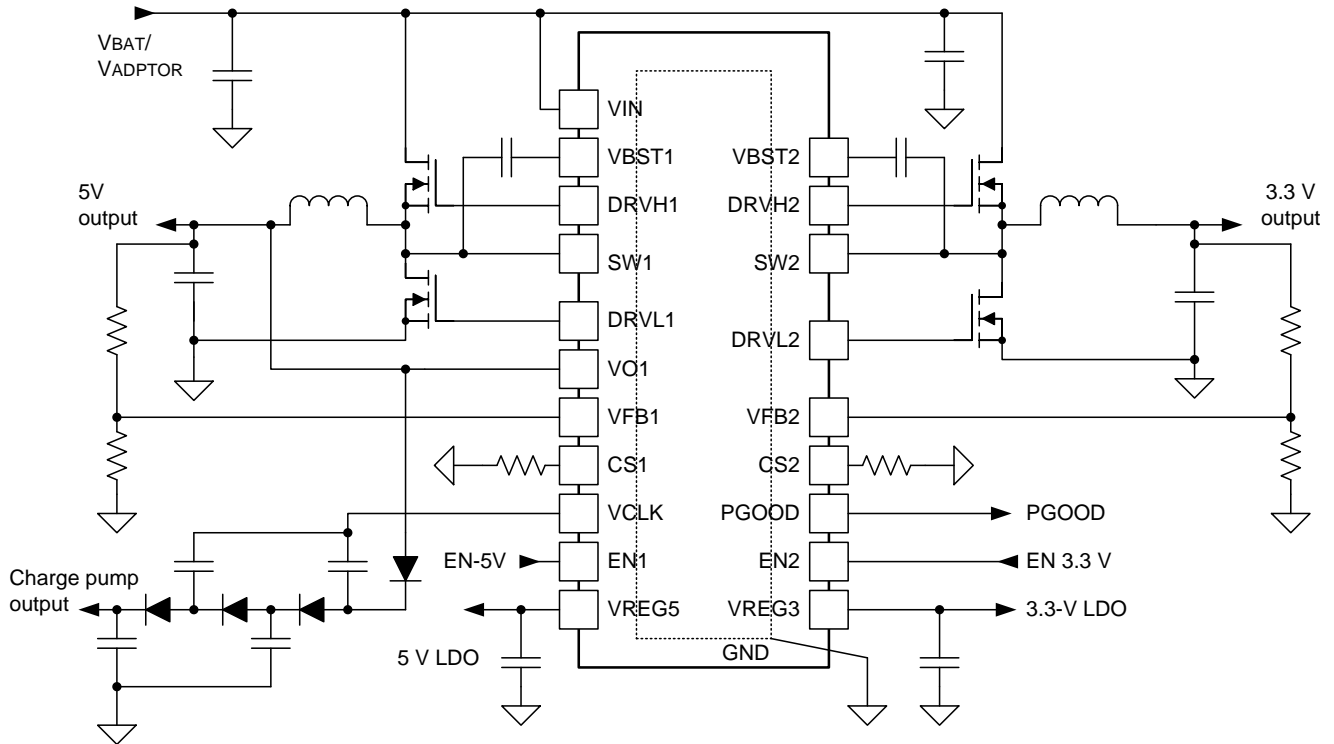

Figure 1. TYPICAL APPLICATION DIAGRAM (With Charge Pump)

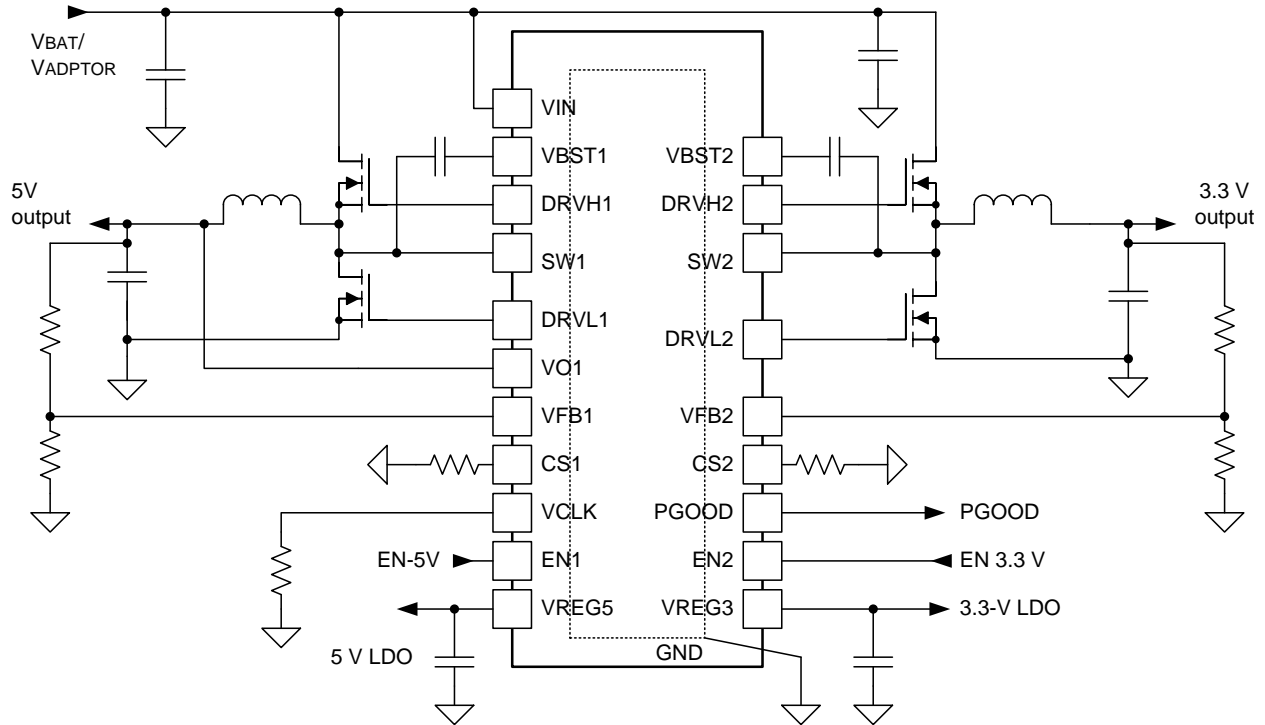

Figure 2. TYPICAL APPLICATION DIAGRAM (Without Charge Pump)

ABSOLUTE MAXIMUM RATINGS⁽¹⁾

over operating free-air temperature range (unless otherwise noted)

		VALUE		UNIT
		MIN	MAX	
Input voltage ⁽²⁾	VBST1, VBST2	-0.3	32	V
	VBST1, VBST2 ⁽³⁾	-0.3	6	
	SW1, SW2	-6	26	
	VIN	-0.3	26	
	EN1, EN2	-0.3	6	
	VFB1, VFB2	-0.3	3.6	
	VO1	-0.3	6	
Output voltage ⁽²⁾	DRVH1, DRVH2	-6.0	32	V
	DRVH1, DRVH2 ⁽³⁾	-0.3	6	
	DRVH1, DRVH2 ⁽³⁾ (duty cycle < 1%)	-2.5	6	
	DRVL1, DRVL2	-0.3	6	
	DRVL1, DRVL2 (duty cycle < 1%)	-2.5	6	
	PGOOD, VCLK, VREG5	-0.3	6	
	VREG3, CS1, CS2	-0.3	3.6	
Electrostatic discharge (ESD) ratings ⁽⁴⁾	Human Body Model (HBM)		2	kV
	Charged Device Model (CDM)		0.5	
Junction temperature, T _J			150	°C
Storage temperature, T _{ST}		-55	150	°C

- (1) Stresses beyond those listed under "absolute maximum ratings" may cause permanent damage to the device. These are stress ratings only and functional operation of the device at these or any other conditions beyond those indicated under "recommended operating conditions" is not implied. Exposure to absolute-maximum-rated conditions for extended periods may affect device reliability.
- (2) All voltage values are with respect to the network ground terminal unless otherwise noted
- (3) Voltage values are with respect to SW terminals.
- (4) ESD testing is performed according to the respective JESD22 JEDEC standard.

THERMAL INFORMATION

THERMAL METRIC ⁽¹⁾		TPS51285A TPS51285B	UNITS
		20-PIN RUK	
θ_{JA}	Junction-to-ambient thermal resistance	46.2	°C/W
θ_{JcTop}	Junction-to-case (top) thermal resistance	53.6	
θ_{JB}	Junction-to-board thermal resistance	19.2	
ψ_{JT}	Junction-to-top characterization parameter	0.6	
ψ_{JB}	Junction-to-board characterization parameter	19.2	
θ_{JcBot}	Junction-to-case (bottom) thermal resistance	3.6	

- (1) For more information about traditional and new thermal metrics, see the IC Package Thermal Metrics application report, [SPRA953](#).

RECOMMENDED OPERATING CONDITIONS

over operating free-air temperature range (unless otherwise noted)

		MIN	TYP	MAX	UNIT
Supply voltage	VIN	5		24	
Input voltage ⁽¹⁾	VBST1, VBST2	-0.1		30	V
	VBST1, VBST2 ⁽²⁾	-0.1		5.5	
	SW1, SW2	-5.5		24	
	EN1, EN2	-0.1		5.5	
	VFB1, VFB2	-0.1		3.5	
	VO1	-0.1		5.5	
Output voltage ⁽¹⁾	DRVH1, DRVH2	-5.5		30	V
	DRVH1, DRVH2 ⁽²⁾	-0.1		5.5	
	DRVL1, DRVL2	-0.1		5.5	
	PGOOD, VCLK, VREG5	-0.1		5.5	
	VREG3, CS1, CS2	-0.1		3.5	
Operating free-air temperature, T _A		-40		85	°C

(1) All voltage values are with respect to the network ground terminal unless otherwise noted.

(2) Voltage values are with respect to the SW terminal.

ELECTRICAL CHARACTERISTICS

over operating free-air temperature range, $V_{VIN} = 12\text{ V}$, $V_{VO1} = 5\text{ V}$, $V_{VFB1} = V_{VFB2} = 2\text{ V}$, $V_{EN1} = V_{EN2} = 3.3\text{ V}$, $V_{CLK}: 200\ \Omega$ to GND

(unless otherwise noted)

PARAMETER		TEST CONDITION	MIN	TYP	MAX	UNIT
SUPPLY CURRENT						
I_{VIN1}	VIN supply current-1	$T_A = 25^\circ\text{C}$, No load, $V_{VO1} = 0\text{ V}$, $V_{VFB1} = V_{VFB2} = 2.06\text{ V}$		84		μA
I_{VIN2}	VIN supply current-2	$T_A = 25^\circ\text{C}$, No load, $V_{VFB1} = V_{VFB2} = 2.06\text{ V}$		10		μA
I_{VO1}	VO1 supply current	$T_A = 25^\circ\text{C}$, No load, $V_{VFB1} = V_{VFB2} = 2.06\text{ V}$		70		μA
$I_{VIN(STBY)}$	VIN stand-by current	TPS51285A		25		μA
		TPS51285B	$T_A = 25^\circ\text{C}$, No load, $V_{VO1} = 0\text{ V}$, $V_{EN1} = V_{EN2} = 0\text{ V}$		28	
INTERNAL REFERENCE						
V_{FBx}	VFB regulation voltage	$T_A = 25^\circ\text{C}$	1.99	2	2.01	V
			1.98	2	2.02	V
I_{FBx}	VFB Leakage Current	$T_A = 25^\circ\text{C}$			0.1	μA
VREG5 OUTPUT						
V_{VREG5}	VREG5 output voltage	$T_A = 25^\circ\text{C}$, No load, $V_{VO1} = 0\text{ V}$	4.9	5	5.1	V
		$V_{VIN} > 7\text{ V}$, $V_{VO1} = 0\text{ V}$, $I_{VREG5} < 100\text{ mA}$	4.85	5	5.1	
		$V_{VIN} > 5.5\text{ V}$, $V_{VO1} = 0\text{ V}$, $I_{VREG5} < 35\text{ mA}$	4.85	5	5.1	
		$V_{VIN} > 5\text{ V}$, $V_{VO1} = 0\text{ V}$, $I_{VREG5} < 20\text{ mA}$	4.55	4.75	5.1	
I_{VREG5}	VREG5 current limit	$V_{VO1} = 0\text{ V}$, $V_{VREG5} = 4.5\text{ V}$, $V_{VIN} = 7\text{ V}$	100	140		mA
R_{V5SW}	5-V switch resistance	$T_A = 25^\circ\text{C}$, $V_{VO1} = 5\text{ V}$, $I_{VREG5} = 50\text{ mA}$		1.8		Ω
VREG3 OUTPUT						
V_{VREG3}	VREG3 output voltage	$V_{VIN} > 7\text{ V}$, $V_{VO1} = 0\text{ V}$, $I_{VREG3} < 100\text{ mA}$	3.217	3.3	3.383	V
		$V_{VIN} > 5.5\text{ V}$, $V_{VO1} = 0\text{ V}$, $I_{VREG3} < 35\text{ mA}$	3.234	3.3	3.366	
		$0^\circ\text{C} \leq T_A \leq 85^\circ\text{C}$, $V_{VIN} > 5.5\text{ V}$, $V_{VO1} = 0\text{ V}$, $I_{VREG3} < 35\text{ mA}$	3.267	3.3	3.333	
		$0^\circ\text{C} \leq T_A \leq 85^\circ\text{C}$, $V_{VIN} > 5.5\text{ V}$, $I_{VREG3} < 35\text{ mA}$	3.267	3.3	3.333	
		$V_{VIN} > 5\text{ V}$, $V_{VO1} = 0\text{ V}$, $I_{VREG3} < 35\text{ mA}$	3.217	3.3	3.366	
$I_{VREG3-1}$	VREG3 current limit-1	$V_{VO1} = 0\text{ V}$, $V_{VREG3} = 3.15\text{ V}$, $V_{VIN} = 7\text{ V}$	100	200		mA
$I_{VREG3-2}$	VREG3 current limit-2	$V_{VREG3} = 3.15\text{ V}$, $V_{VIN} = 7\text{ V}$	100	200		
DUTY CYCLE and FREQUENCY CONTROL						
f_{sw1}	CH1 frequency ⁽¹⁾	$T_A = 25^\circ\text{C}$, $V_{VIN} = 20\text{ V}$		400		kHz
f_{sw2}	CH2 frequency ⁽¹⁾	$T_A = 25^\circ\text{C}$, $V_{VIN} = 20\text{ V}$		475		kHz
$t_{OFF(MIN)}$	Minimum off-time	$T_A = 25^\circ\text{C}$	200	300	400	ns
MOSFET DRIVERS						
R_{DRVH}	DRVH resistance	Source, $I_{DRVH} = -50\text{ mA}$, $(V_{VBST} - V_{SW}) = 5\text{ V}$		3		Ω
		Sink, $I_{DRVH} = 50\text{ mA}$, $(V_{VBST} - V_{SW}) = 5\text{ V}$		1.9		
R_{DRVL}	DRVL resistance	Source, $I_{DRVL} = -50\text{ mA}$, $V_{VREG5} = 5\text{ V}$		3		Ω
		Sink, $I_{DRVL} = 50\text{ mA}$, $V_{VREG5} = 5\text{ V}$		0.9		
t_D	Dead time	DRVH-off to DRVL-on		12		ns
		DRVL-off to DRVH-on		20		
INTERNAL BOOT STRAP SWITCH						
$R_{VBST(ON)}$	Boost switch on-resistance	$T_A = 25^\circ\text{C}$, $I_{VBST} = 10\text{ mA}$		13		Ω
I_{VBSTLK}	VBST leakage current	$T_A = 25^\circ\text{C}$			1	μA
CLOCK OUTPUT						
R_{VCLK}	VCLK on-resistance (pull-up)	$T_A = 25^\circ\text{C}$, VCLK: Open		10		Ω
	VCLK on-resistance (pull-down)	$T_A = 25^\circ\text{C}$, VCLK: Open		10		
f_{CLK}	Clock frequency	$T_A = 25^\circ\text{C}$, VCLK: Open		256		kHz

(1) Specified by design. Not production tested.

ELECTRICAL CHARACTERISTICS (continued)

over operating free-air temperature range, $V_{VIN} = 12\text{ V}$, $V_{VO1} = 5\text{ V}$, $V_{VFB1} = V_{VFB2} = 2\text{ V}$, $V_{EN1} = V_{EN2} = 3.3\text{ V}$, $V_{CLK} = 200\ \Omega$ to GND

(unless otherwise noted)

PARAMETER		TEST CONDITION	MIN	TYP	MAX	UNIT
OUTPUT DISCHARGE						
R_{DIS1}	CH1 discharge resistance	$T_A = 25^\circ\text{C}$, $V_{VO1} = 0.5\text{ V}$ $V_{EN1} = V_{EN2} = 0\text{ V}$		35		Ω
R_{DIS2}	CH2 discharge resistance	TPS51285A		75		Ω
		TPS51285B	$T_A = 25^\circ\text{C}$, $V_{SW2} = 0.5\text{ V}$, $V_{EN1} = V_{EN2} = 0\text{ V}$	70		
SOFT START						
t_{SS}	Soft-start time (From ENx Hi)	From ENx="Hi" and $V_{VREG5} > V_{UVLO5}$ to $V_{OUT} = 95\%$		0.91		ms
t_{SSRAMP}	Soft-start time (ramp-up)	$V_{OUT} = 0\%$ to $V_{OUT} = 95\%$, $V_{VREG5} = 5\text{ V}$		0.78		ms
POWER GOOD						
t_{PGDEL}	PG start-up delay	From EN1 = "Hi", EN2 = "Hi", and $V_{VREG5} > V_{UVLO5}$		1.65		ms
V_{PGTH}	PG threshold	PGOOD in from lower (start-up)	87.5%	90%	92.5%	
I_{PGMAX}	PG sink current	$V_{PGOOD} = 0.5\text{ V}$		6.5		mA
I_{PGLK}	PG leak current	$V_{PGOOD} = 5.5\text{ V}$			1	μA
CURRENT SENSING						
I_{CS}	CS source current	$T_A = 25^\circ\text{C}$, $V_{CS} = 0.4\text{ V}$	45	50	55	μA
TC_{CS}	CS current temperature coefficient ⁽²⁾	On the basis of 25°C		4500		ppm/ $^\circ\text{C}$
V_{CS}	CS Current limit setting range		0.2		2	V
V_{AZCADJ}	Adaptive zero cross adjustable range	Positive	5	10		mV
		Negative		-10	-5	
LOGIC THRESHOLD						
$V_{ENX(ON)}$	EN threshold high-level	SMPS on level			1.6	V
$V_{ENX(OFF)}$	EN threshold low-level	SMPS off level	0.3			V
I_{EN}	EN input current	$V_{ENx} = 3.3\text{ V}$			1	μA
OUTPUT OVERVOLTAGE PROTECTION						
V_{OVP}	OVP trip threshold		112.5%	115%	117.5%	
t_{OVPDLY}	OVP propagation delay	$T_A = 25^\circ\text{C}$		0.5		μs
OUTPUT UNDERVOLTAGE PROTECTION						
V_{UVP}	UVP trip Threshold		55%	60%	65%	
V_{UVP-ST}	UVP trip Threshold	Start Up	87.5%	90%	92.5%	
t_{UVPDLY}	UVP prop delay			250		μs
$t_{UVPENDLY}$	UVP enable delay	From ENx = "Hi", $V_{VREG5} = 5\text{ V}$		1.1		ms
UVLO						
$V_{UVLOVIN}$	VIN UVLO Threshold	Wake up	4.2	4.58	4.95	V
		Shutdown	3.75	4.1	4.45	V
V_{UVLO5}	VREG5 UVLO Threshold	Wake up	4.08	4.38	4.55	V
		Shutdown	3.7	4	4.3	V
V_{UVLO3}	VREG3 UVLO Threshold	Wake up	3	3.15	3.26	V
		Shutdown	2.75	3	3.21	V

(2) Specified by design. Not production tested.

FUNCTIONAL BLOCK DIAGRAM

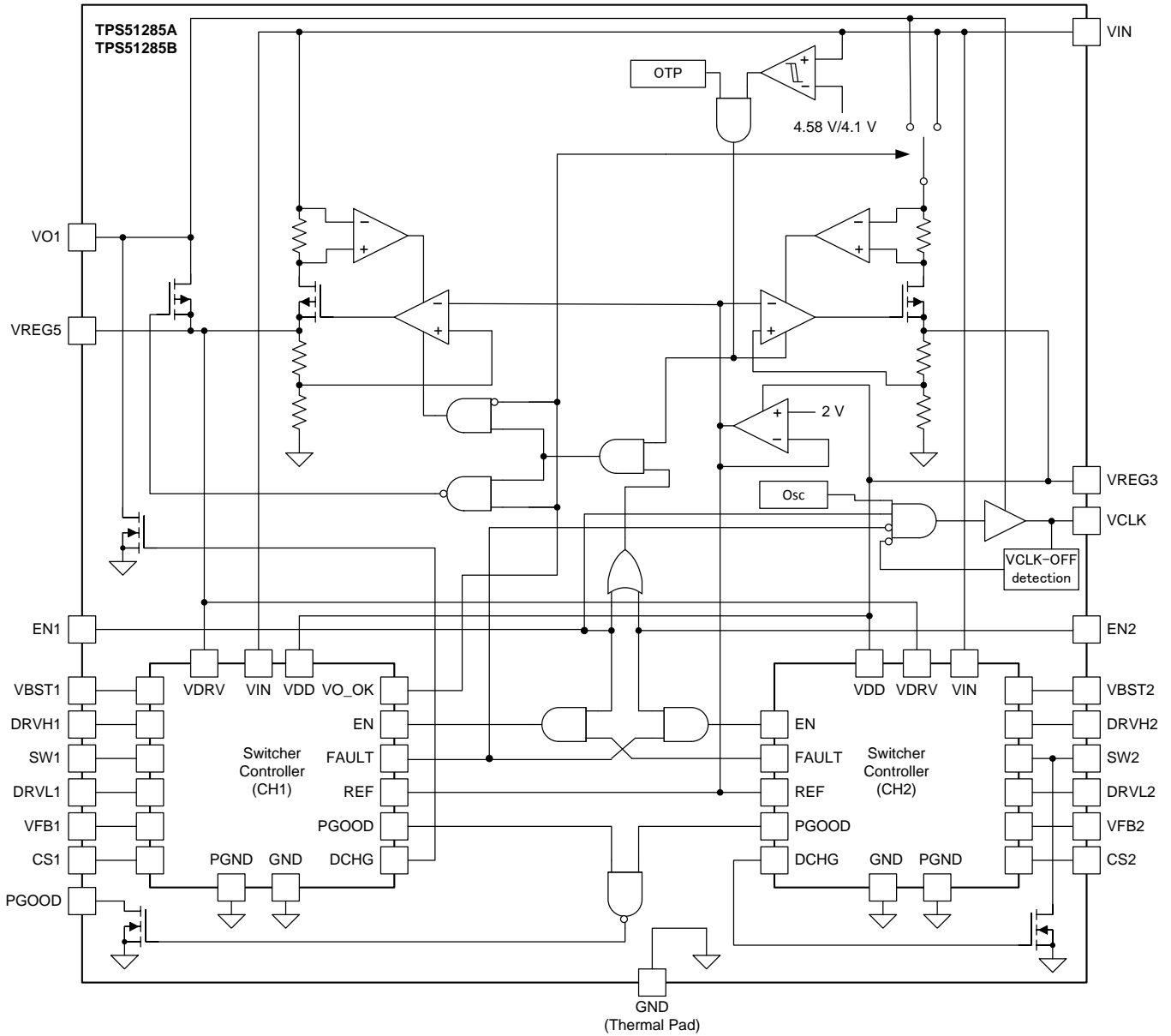

SWITCHER CONTROLLER BLOCK DIAGRAM

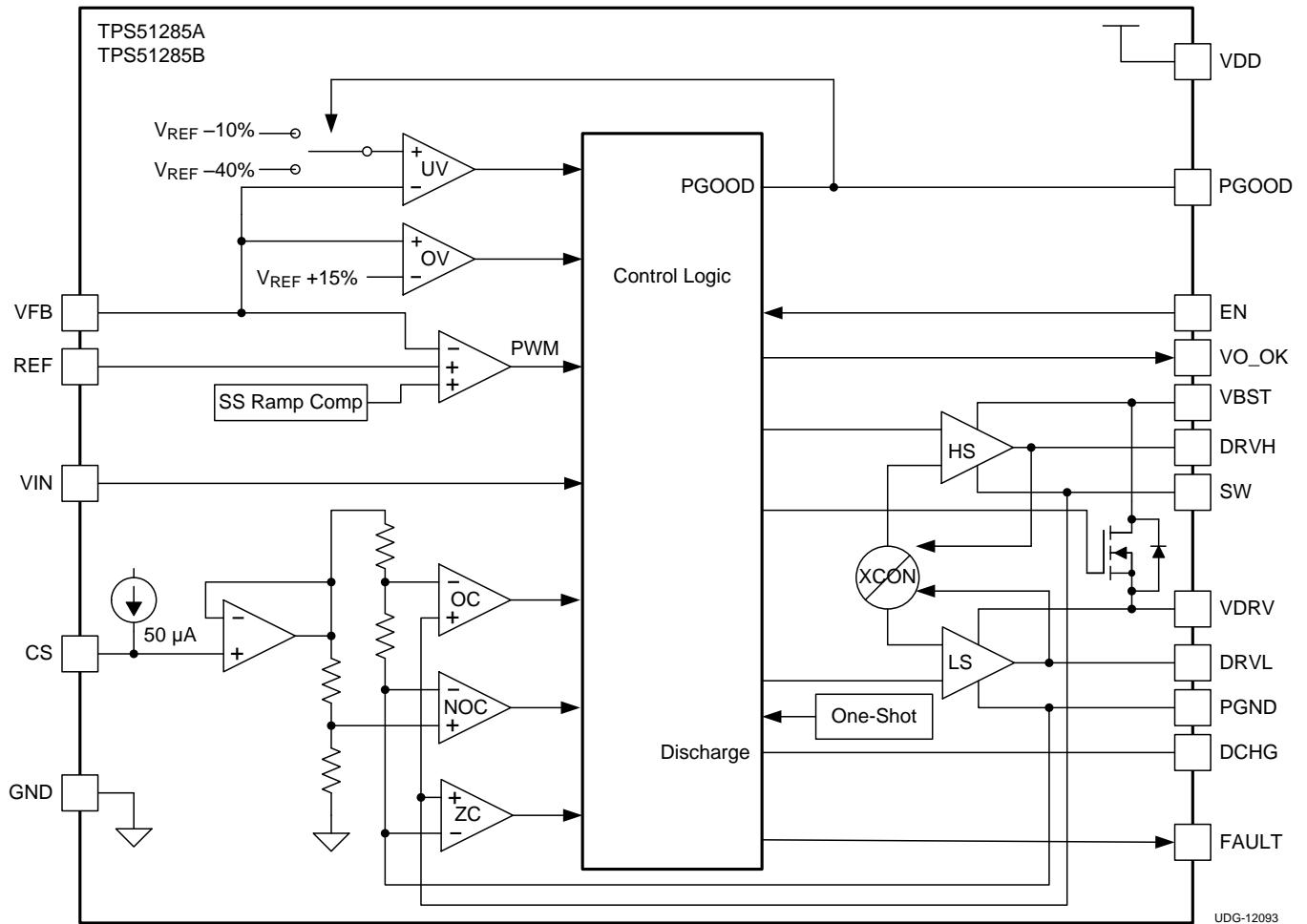

DETAILED DESCRIPTION

PWM Operations

The main control loop of the switch mode power supply (SMPS) is designed as an adaptive on-time pulse width modulation (PWM) controller. It supports a proprietary D-CAP™ mode. D-CAP™ mode does not require external compensation circuits and is suitable for low external component count configuration when used with appropriate amount of ESR at the output capacitor(s).

At the beginning of each cycle, the synchronous high-side MOSFET is turned on, or enters the ON state. This MOSFET is turned off, or enters the 'OFF state, after the internal, one-shot timer expires. The MOSFET is turned on again when the feedback point voltage, V_{VFB} , decreased to match the internal 2-V reference. The inductor current information is also monitored and should be below the overcurrent threshold to initiate this new cycle. By repeating the operation in this manner, the controller regulates the output voltage. The synchronous low-side (rectifying) MOSFET is turned on at the beginning of each OFF state to maintain a minimum of conduction loss. The low-side MOSFET is turned off before the high-side MOSFET turns on at next switching cycle or when the detecting inductor current decreases to zero. This enables seamless transition to the reduced frequency operation during light-load conditions so that high efficiency is maintained over a broad range of load current.

Adaptive On-Time/ PWM Frequency Control

Because the device does not have a dedicated oscillator for control loop on board, switching cycle is controlled by the adaptive on-time circuit. The on-time is controlled to meet the target switching frequency by forwarding the input and output voltage into the on-time one-shot timer. To achieve higher duty operation for lower input voltage application (2-cell battery), the target switching frequency is varied according to the input voltage. The switching frequency of CH1 (5-V output) is 400kHz during continuous conduction mode (CCM) operation when $V_{IN} = 20$ V. The CH2 (3.3-V output) is 475 kHz during CCM when $V_{IN} = 20$ V.

To improve load transient performance and load regulation in lower input voltage condition, device can extend the on-time. The maximum on-time extension of CH1 is 5 times. For CH2, it is 2 times. To maintain a reasonable inductor ripple current during on-time extension, the inductor ripple current should be set to less than half of the OCL (valley) threshold. The on-time extension function provides high duty cycle operation and shows better DC (static) performance. AC performance is determined mostly by the output LC filter and resistive factor in the loop.

Light Load Condition in Auto-Skip Operation

The device automatically reduces switching frequency during light-load conditions to maintain high efficiency. This reduction of frequency is achieved smoothly. A more detailed description of this operation is as follows. As the output current decreases from heavy-load condition, the inductor current is also reduced and eventually approaches valley zero current, which is the boundary between continuous conduction mode and discontinuous conduction mode. The rectifying MOSFET is turned off when this zero inductor current is detected. As the load current further decreases, the converter runs in discontinuous conduction mode and it takes longer and longer to discharge the output capacitor to the level that requires the next ON cycle. In reverse, when the output current increase from light load to heavy load, the switching frequency increases to the preset value as the inductor current reaches to the continuous conduction. The transition load point to the light load operation $I_{OUT(LL)}$ (that is, the threshold between continuous and discontinuous conduction mode) can be calculated as shown in [Equation 1](#).

$$I_{OUT(LL)} = \frac{1}{2 \times L \times f_{SW}} \times \frac{(V_{IN} - V_{OUT}) \times V_{OUT}}{V_{IN}}$$

where

- f_{SW} is the PWM switching frequency (1)

Switching frequency versus output current during light-load conditions is a function of inductance (L), input voltage (V_{IN}) and output voltage (V_{OUT}), but it decreases almost proportional to the output current from the $I_{OUT(LL)}$.

ULQ™ Mode

To achieve longer battery life in system stand-by mode of mobile devices, the device implements Ultra Low Quiescent (ULQ) mode. In the ULQ mode, the device consumes low quiescent current (see the [ELECTRICAL CHARACTERISTICS](#) table). Therefore, high efficiency can be obtained in the system stand-by mode. The TPS51285A/B enters the ULQ mode automatically (no control input signal is required) when both high-side and low-side MOSFET drivers are OFF state in discontinuous conduction operation. It exits from the ULQ mode when the PWM comparator detects VFB drops to the internal 2-V VREF and turns on the high-side MOSFET. In the ULQ mode, all protection functions are active.

D-CAP™ Mode

From small-signal loop analysis, a buck converter using D-CAP™ mode can be simplified as shown in [Figure 3](#).

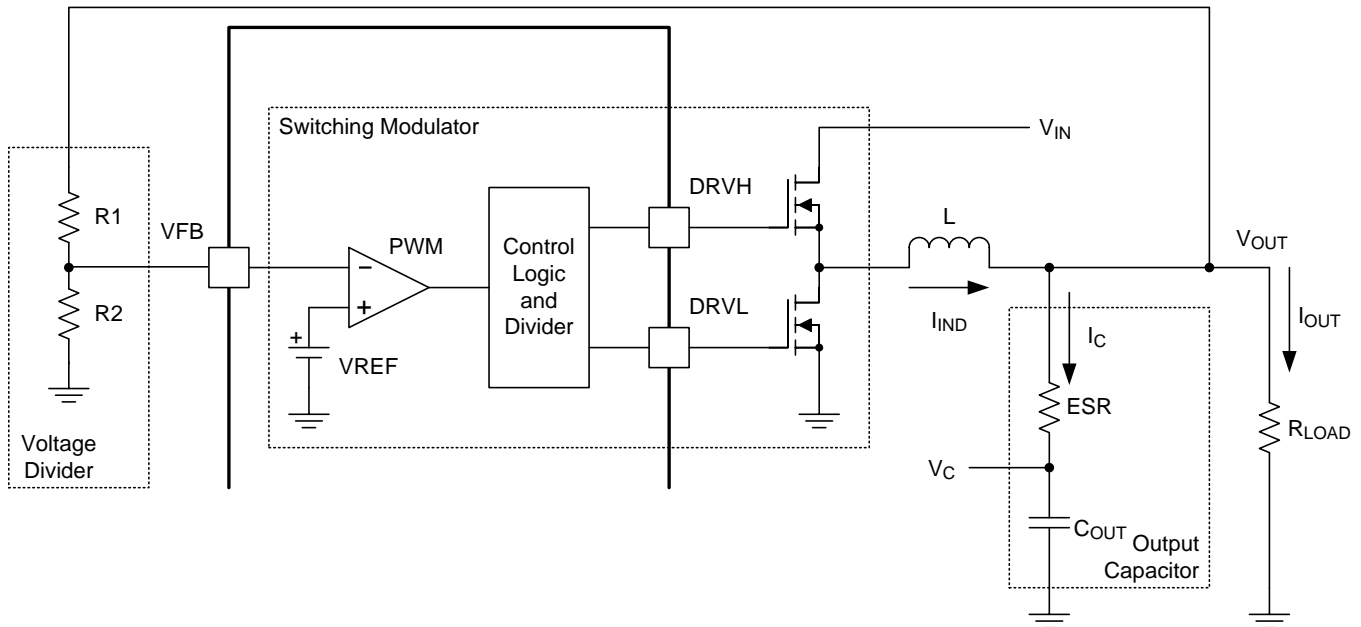

Figure 3. Simplifying the Modulator

The output voltage is compared with internal reference voltage after divider resistors, R1 and R2. The PWM comparator determines the timing to turn on the high-side MOSFET. The gain and speed of the comparator is high enough to keep the voltage at the beginning of each ON cycle substantially constant. For the loop stability, the 0 dB frequency, f_0 , defined in [Equation 2](#) must be lower than 1/4 of the switching frequency.

$$f_0 = \frac{1}{2\pi \times \text{ESR} \times C_{\text{OUT}}} \leq \frac{f_{\text{SW}}}{4} \quad (2)$$

As f_0 is determined solely by the output capacitor characteristics, the loop stability during D-CAP™ mode is determined by the capacitor chemistry. For example, specialty polymer capacitors have output capacitance in the order of several hundred micro-Farads and ESR in range of 10 milli-ohms. These yield an f_0 value on the order of 100 kHz or less and the loop is stable. However, ceramic capacitors have f_0 at more than 700 kHz, which is not suitable for this operational mode.

Enable and Power Good

VREG3 is an always-on regulator (TPS51285A and TPS1285B), For TPS51285B, VREG5 is an always-on LDO, too (See [Table 1](#) and [Table 2](#)). When VIN exceeds the VIN-UVLO threshold VREG3 turns on. For TPS51285B, VREG5 turns on when VREG3 exceeds 2.4V. For TPS51285A, VREG5 turns on when either EN1 or EN2 enters ON state in addition to the above VREG3 threshold. CH1's or CH2's output starts ramping up when the corresponding EN pin is in the ON state and VREG5 is larger than the VREG5-UVLO. VCLK initiates switching when EN1 enters ON state. The state controls are shown in [Table 1](#) and [Table 2](#).

TPS51285A and TPS51285B have a PGOOD open drain output. During the start-up, if the feedback voltages for both CH1 and CH2 exceed 90% of the reference voltage, the PGOOD becomes high with defined PGOOD delay time. During the operation, if the feedback voltage rise beyond 115%(typ) for either switching regulator, PGOOD turns low. If the feedback voltage falls below 60%(typ), the PGOOD turns low.

Table 1. Enabling and PGOOD State (TPS51285A; Always-on VREG3)

EN1	EN2	VREG5	VREG3	CH1 (5Vout)	CH2 (3.3Vout)	VCLK	PGOOD
OFF	OFF	OFF	ON	OFF	OFF	OFF	Low
ON	OFF	ON	ON	ON	OFF	ON	Low
OFF	ON	ON	ON	OFF	ON	OFF	Low
ON	ON	ON	ON	ON	ON	ON	High

Table 2. Enabling and PGOOD State (TPS51285B; Always-on VREG3 and VREG5)

EN1	EN2	VREG5	VREG3	CH1 (5Vout)	CH2 (3.3Vout)	VCLK	PGOOD
OFF	OFF	ON	ON	OFF	OFF	OFF	Low
ON	OFF	ON	ON	ON	OFF	ON	Low
OFF	ON	ON	ON	OFF	ON	OFF	Low
ON	ON	ON	ON	ON	ON	ON	High

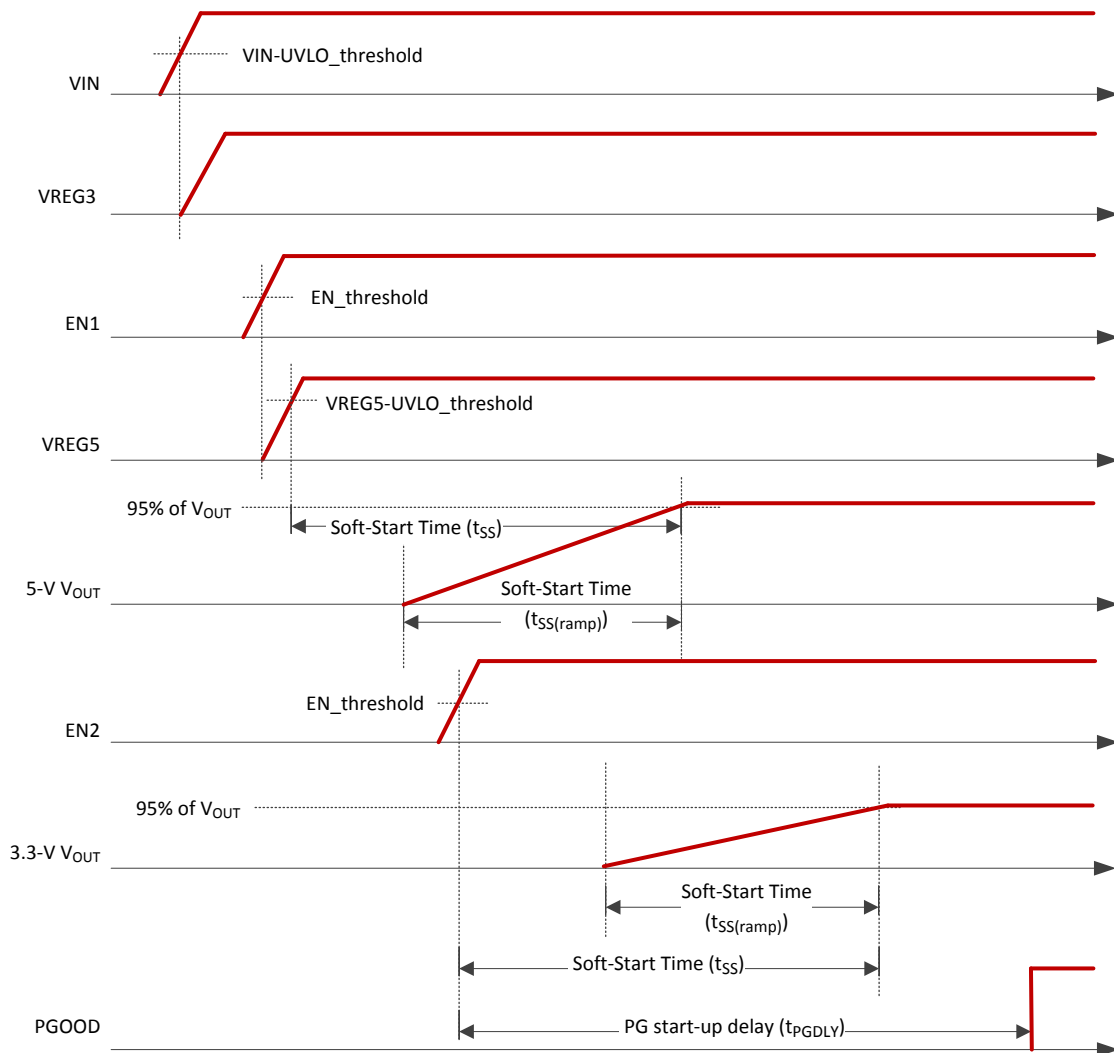

Figure 4. TPS51285A Timing Diagram of Start-up

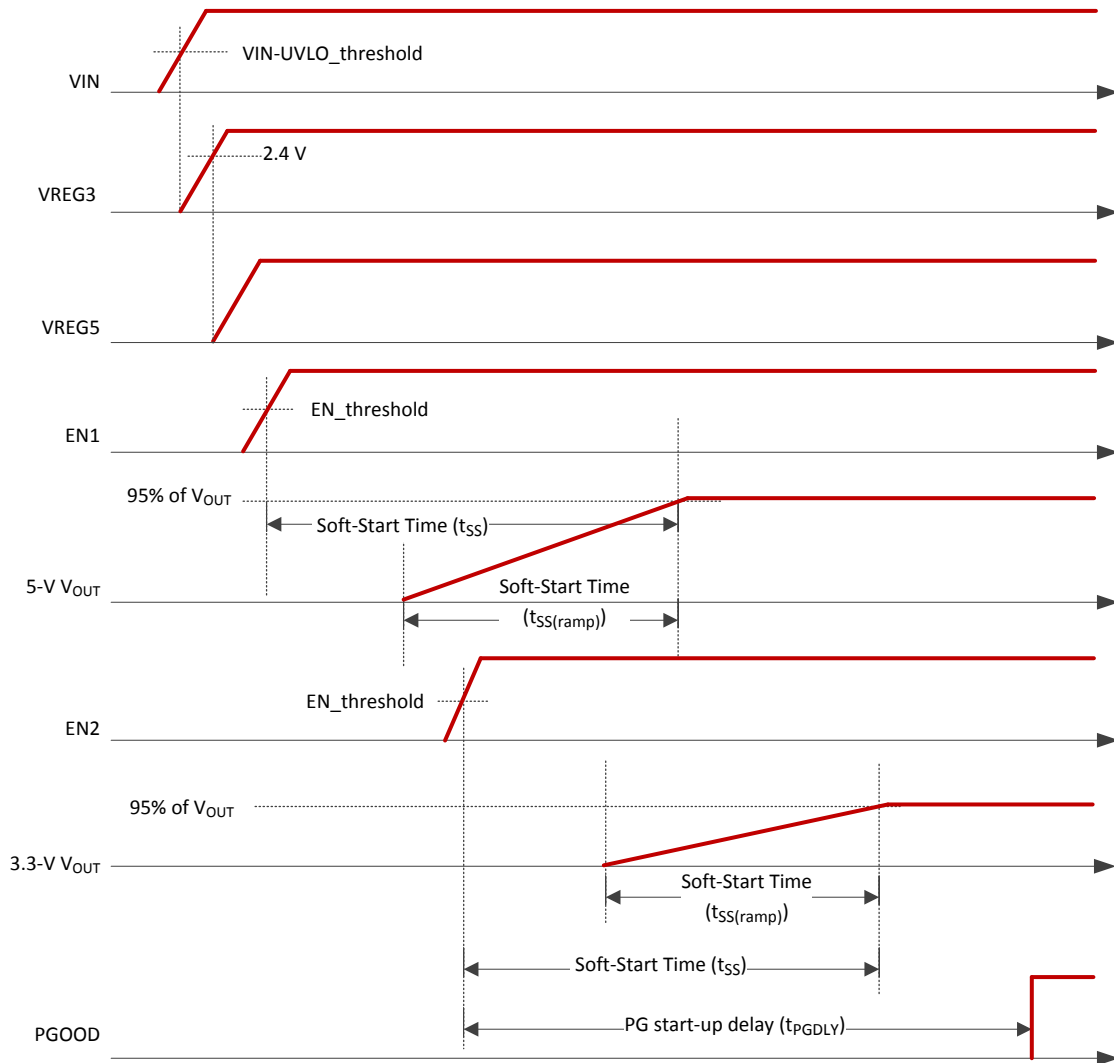

Figure 5. TPS51285B Timing Diagram of Start-up

Soft-Start and Discharge

The TPS51285A and TPS51285B operates an internal, 0.8-ms, voltage servo soft-start for each channel. When the ENx pin becomes higher than the enable threshold voltage, an internal DAC begins ramping up the reference voltage to the target (2 V). Smooth control of the output voltage is maintained during start-up. When ENx becomes lower than the lower level of threshold voltage, the device discharges outputs using internal MOSFETs through VO1 (CH1) and SW2 (CH2).

VREG5 and VREG3 Linear Regulators

There are two 100-mA standby linear regulators that output 5 V and 3.3 V, respectively. The VREG5 provides the current for gate drivers. VREG3 functions as the main power supply for the analog circuitry of the device.

A ceramic capacitor with a value of 4.7 μF or larger (X5R grade or better) is required for each of VREG5 and VREG3. It should be placed close to the VREG5 pin and the VREG3 pin respectively to stabilize the LDOs.

The VREG5 pin switchover function is asserted when three conditions are present:

- CH1 is not in UVP/OVP condition
- CH1 is not in OCL condition
- VO1 voltage is higher than (VREG5 -1V)

In this switchover condition three things occur:

- the internal 5-V LDO regulator is shut off
- the VREG5 output is connected to VO1 by internal switchover MOSFET
- VREG3 input pass is changed from VIN to VO1

VCLK for Charge Pump

A 256 kHz VCLK signal can be used for the external charge pump circuit. The VCLK signal becomes available when EN1 enters ON state. VCLK driver circuit is driven by VO1 voltage. In a design that does not require VCLK output, tie 200 Ω between VCLK pin and GND so that VCLK is turned off.

Overcurrent Protection

TPS51285A and TPS51285B have cycle-by-cycle over current limiting control. The inductor current is monitored during the OFF state and the controller maintains the OFF state during the inductor current is larger than the overcurrent trip level. In order to provide both good accuracy and cost effective solution, the device supports temperature compensated MOSFET $R_{\text{DS(on)}}$ sensing. The CSx pin should be connected to GND through the CS voltage setting resistor, R_{CS} . The CSx pin sources CS current (I_{CS}) which is 50 μA typically at room temperature, and the CSx terminal voltage ($V_{\text{CS}} = R_{\text{CS}} \times I_{\text{CS}}$) should be in the range of 0.2 V to 2 V over all operation temperatures. The trip level is set to the OCL trip voltage (V_{TRIP}) as shown in [Equation 3](#).

$$V_{\text{TRIP}} = \frac{R_{\text{CS}} \times I_{\text{CS}}}{8} + 1 \text{ mV} \quad (3)$$

The inductor current is monitored by the voltage between GND pin and SWx pin so that SWx pin should be connected to the drain terminal of the low-side MOSFET properly. The CS pin current has a 4500 ppm/ $^{\circ}\text{C}$ temperature slope to compensate the temperature dependency of the $R_{\text{DS(on)}}$. GND is used as the positive current sensing node so that GND should be connected to the source terminal of the low-side MOSFET.

As the comparison is done during the OFF state, V_{TRIP} sets the valley level of the inductor current. Thus, the load current at the overcurrent threshold, $I_{\text{OCL(DC)}}$, can be calculated as shown in [Equation 4](#).

$$I_{\text{OCL(DC)}} = \frac{V_{\text{TRIP}}}{R_{\text{DS(on)}}} + \frac{I_{\text{IND(ripple)}}}{2} = \frac{V_{\text{TRIP}}}{R_{\text{DS(on)}}} + \frac{1}{2 \times L \times f_{\text{SW}}} \times \frac{(V_{\text{IN}} - V_{\text{OUT}}) \times V_{\text{OUT}}}{V_{\text{IN}}} \quad (4)$$

In an overcurrent condition, the current to the load exceeds the current to the output capacitor thus the output voltage tends to fall down. Eventually, it ends up with crossing the undervoltage protection threshold and shutdown both channels.

Table 3. Key External Components

REFERENCE DESIGNATOR	FUNCTION	MANUFACTURER	PART NUMBER
L1	Output Inductor (5-Vout)	ALPS	GLMC3R303A
L2	Output Inductor (3.3-Vout)	ALPS	GLMC2R203A
C3	Output Capacitor (5-Vout)	SANYO	6TPS220MAZB x 2
C4	Output Capacitor (3.3-Vout)	SANYO	6TPS220MAZB x 2
Q1	MOSFET (5-Vout)	TI	CSD87330Q3D
Q2	MOSFET (3.3-Vout)	TI	CSD87330Q3D
C5	Decoupling Capacitance (VREG5)	MURATA	GRM188B30J475ME84
C6	Decoupling Capacitance (VREG3)	MURATA	GRM188B30J475ME84

Design Procedure

Step 1. Determine the Specifications:

- VIN range = 5.5 V to 20 V
- CH1 output: Vout1 = 5 V and Iout1 = 6 A
- CH2 output: Vout2 = 3.3 V and Iout2 = 7 A

Step 2. Determine the Value of Voltage Divider Resistors

The output voltage is determined by 2-V internal voltage reference and the resistor dividers (R1 and R2/ R4 and R5). To achieve higher efficiency at light load condition, for 5 V output, select R2 = 100 kΩ and R1 = 150kΩ for 3.3V output R5 = 200 kΩ and R4 = 130 kΩ. Determine R1 using Equation 5. (for 3.3 V, replace R1 with R4 and R2 with R5). For applications where signal-to-noise performance is more valuable than light load efficiency, set R2 (R5) to 10kΩ.

$$R1 = \frac{(V_{OUT} - 0.5 \times V_{RIPPLE} - 2.0)}{2.0} \times R2 \quad (5)$$

Step 3. Determine Inductance and Choose the Inductor

Smaller inductance yields better transient performance but the consequence is larger ripple and lower efficiency. Larger value has the opposite characteristics. It is the common practice to limit the inductor ripple current to 25% to 50% of the maximum output current. In this case, use 50% at VIN = 20 V.

$$L1 = \frac{1}{I_{IND(ripple)} \times f_{SW(CH1)}} \times \frac{(V_{IN(max)} - V_{OUT}) \times V_{OUT}}{V_{IN(max)}} = 3.13 \mu H \quad (6)$$

Where

- IIND(ripple) = 6 A x 0.5, VOUT = 5 V. VIN(MAX) = 20 V, fSW(CH2) = 400 kHz

$$L2 = \frac{1}{I_{IND(ripple)} \times f_{SW(CH2)}} \times \frac{(V_{IN(max)} - V_{OUT}) \times V_{OUT}}{V_{IN(max)}} = 1.66 \mu H \quad (7)$$

Where

- IIND(ripple) = 7 A x 0.5, VOUT = 3.3 V. VIN(MAX) = 20 V, fSW(CH2) = 475 kHz

For this design, L1 = 3.3 μH and L2 = 2.2 μH are chosen.

Step 4. Choose Output Capacitor(s)

For the loop stability, the 0 dB frequency, f_0 , defined in Equation 8 must be lower than 1/4 of the switching frequency (entire V_{IN} range).

$$f_0 = \frac{1}{2\pi \times ESR \times C_O} \leq \frac{f_{SW}}{4} \quad (8)$$

Determine ESR to meet required ripple voltage below for better jitter performance. A quick approximation is as shown in Equation 9.

$$ESR = \frac{V_{OUT} \times 20[mV] \times (1-D)}{2[V] \times I_{IND(Ripple)}} = \frac{20[mV] \times L \times f_{SW}}{2[V]} \quad (9)$$

where

- D as the duty-cycle factor
- the required output ripple voltage slope is approximately 20 mV per t_{SW} (switching period) in terms of VFB terminal

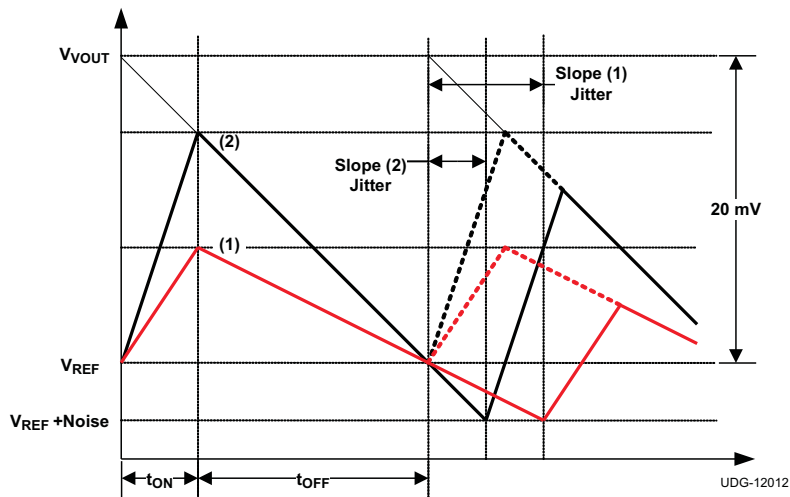

Figure 7. Ripple Voltage Slope and Jitter Performance

This design uses 2 x 220 μ F (35 m Ω) for each output.

Step 5. Determine Over Current Limit (OCL) Setting Resistors

Use Equation 10 to determine the over current limit setting resistor (R_3/ R_6) which is connected from CS1/CS2 to GND.

$$R_{CS} = \frac{8}{I_{CS}} \times \left[(I_{OCL(DC)} - I_{IND(ripple)} \times 0.5) \times R_{DS(ON)} - 1mV \right] \quad (10)$$

Confirm CS voltage is within the range of 0.2 V to 2 V over all operation temperature using Equation 11.

$$V_{CS} = R_{CS} \times I_{CS} \left[(25^\circ C - T_A) \times TC_{CS} \times 10^{-6} + 1 \right] \quad (11)$$

Where

- T_A is an operation temperature

Confirm inductor ripple current is less than half of OCL (valley) using Equation 12

$$I_{IND(ripple)} < \frac{I_{OCL(VALLEY)}}{2} = \frac{\left(\frac{R_{CS} \times I_{CS}}{8} + 1mV \right)}{2 \times R_{DS(ON)}} \quad (12)$$

This design uses CSD87330Q3D (low-side $R_{DS(ON)}$ typ = 4.7 m Ω) and R3 ($R_{CS} - CH1$) = 6.19 k Ω , R6 ($R_{CS} - CH2$) = 6.65 k Ω .

Step 6. Select Decoupling Capacitors

Use ceramic capacitors with a value of 4.7 μF or larger (X5R grade or better) for C5 (VREG5) and C6 (VREG3). For the V_{IN} input capacitors (C1 and C2), 2 x 10 μF (1206, 25V, X5R) MLCC per channel is used in the design. Tighter tolerances and higher voltage ratings are always appreciated.

Step 7. Peripheral Components

For high-side N-channel MOSFET drive circuit, connect boot strap capacitor between VBSTx and SWx . To control gate driver strength, adding a resistor (reserved space) is recommended. This design uses 0.1 μF (C7 and C8), 0 Ω (R7 and R8), 6.8 Ω (R9) and 8.2 Ω (R10).

Step 8. Charge Pump Design

Figure 6 shows a circuit design without an external charge pump. Add R11 = 200 Ω from VCLK to GND to disable VCLK signal. Figure 8 shows the design with an external charge pump. D1 (4-in 1 Diode: BAS40DW-04) should be tied to the 5V switcher output and 4 x 0.1 μF (C9, C10, C11 and C12) is used.

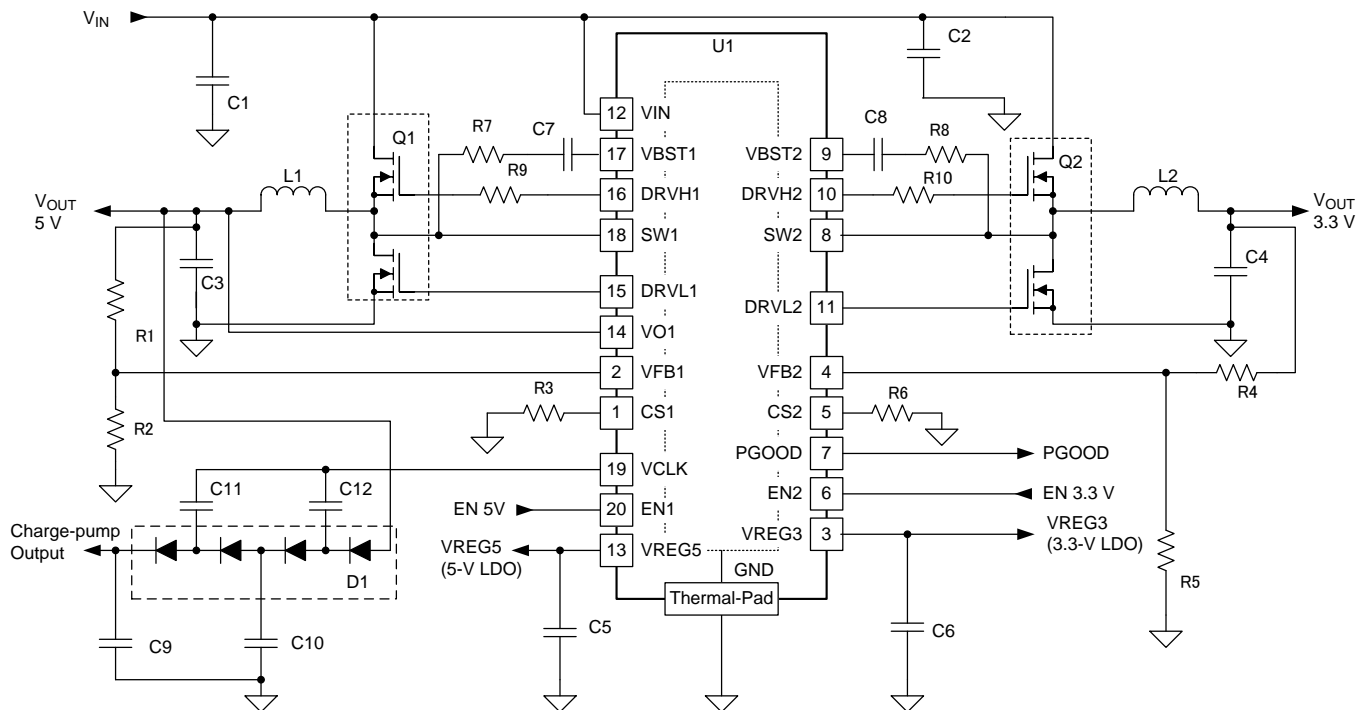

Figure 8. Application Schematic (with Charge pump)

Layout Considerations

Good layout is essential for stable power supply operation. Follow these guidelines for an efficient PCB layout.

Placement

- Place voltage setting resistors close to the device pins.
- Place bypass capacitors for VREG5 and VREG3 close to the device pins.

Routing (Sensitive analog portion)

- Use small copper space for VFBx. There are short and narrow traces to avoid noise coupling.
- Connect VFB resistor trace to the positive node of the output capacitor. Routing inner layer away from power traces is recommended.
- Use short and wide trace from VFB resistor to vias to GND (internal GND plane).

Routing (Power portion)

- Use wider/shorter traces of DRV1 for low-side gate drivers to reduce stray inductance.
- Use the parallel traces of SW and DRVH for high-side MOSFET gate drive in a same layer or on adjoint layers, and keep them away from DRV1.
- Use wider/ shorter traces between the source terminal of the high-side MOSFET and the drain terminal of the low-side MOSFET
- Thermal pad is the GND terminal of this device. Five or more vias with 0.33-mm (13-mils) diameter connected from the thermal pad to the internal GND plane should be used to have strong GND connection and help heat dissipation.

TYPICAL CHARACTERISTICS

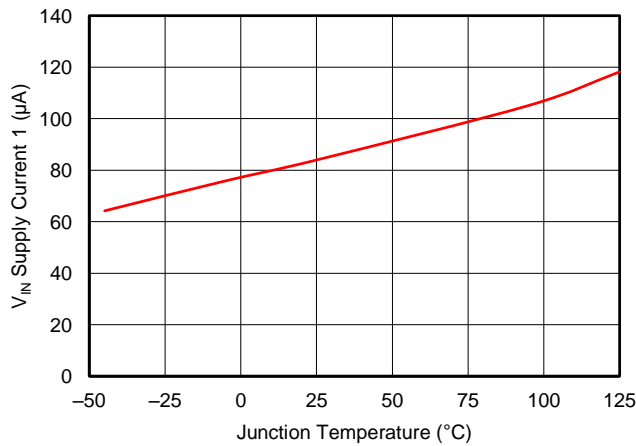

Figure 9. VIN Supply Current 1 vs. Junction Temperature

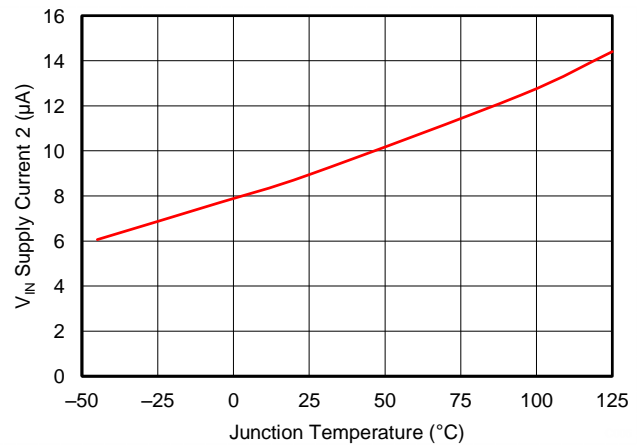

Figure 10. VIN Supply Current 2 vs. Junction Temperature

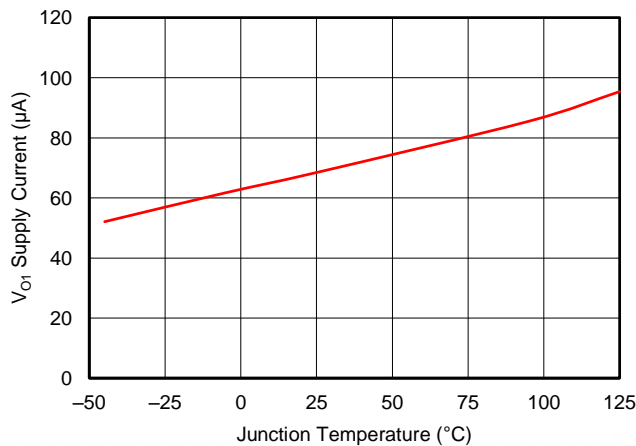

Figure 11. VO1 Supply Current 1 vs. Junction Temperature

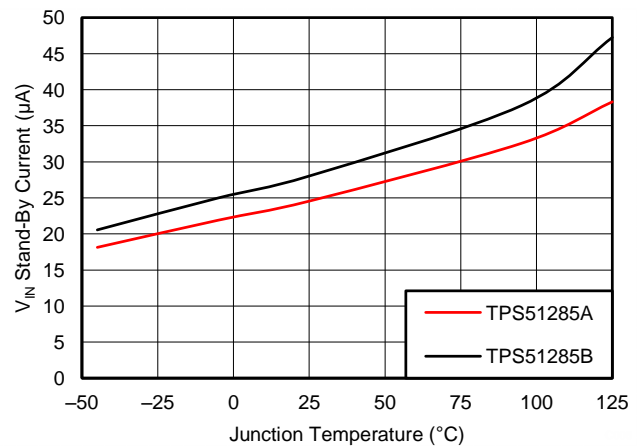

Figure 12. VIN Stand-By Current vs. Junction Temperature

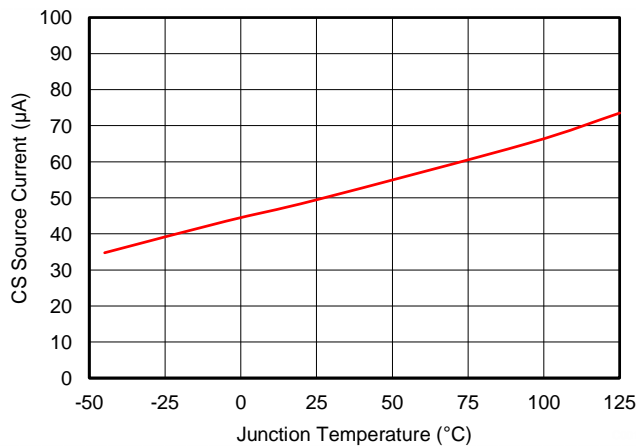

Figure 13. CS Source Current vs. Junction Temperature

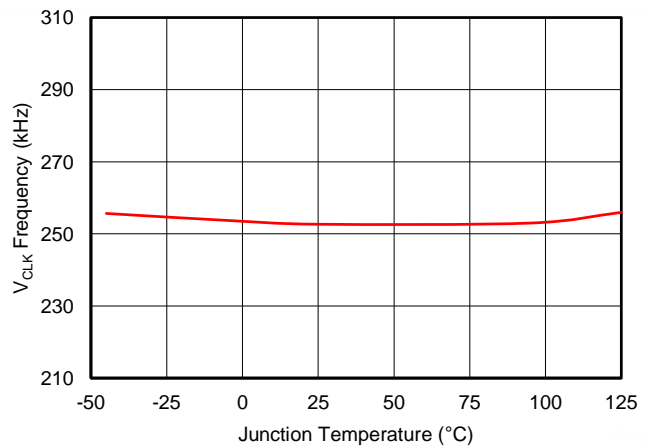

Figure 14. Clock Frequency vs. Junction Temperature

TYPICAL CHARACTERISTICS (continued)

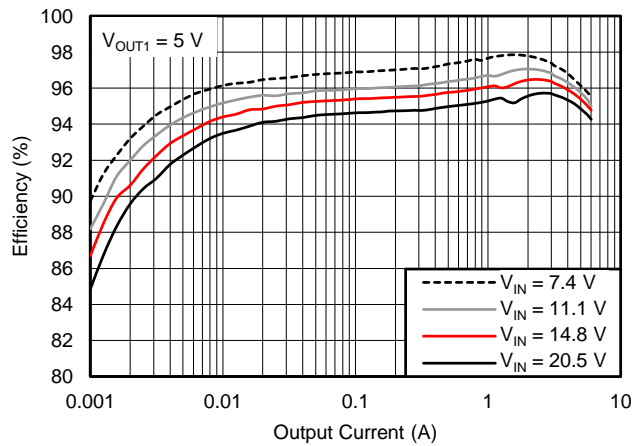

Figure 15. Efficiency vs. Output Current

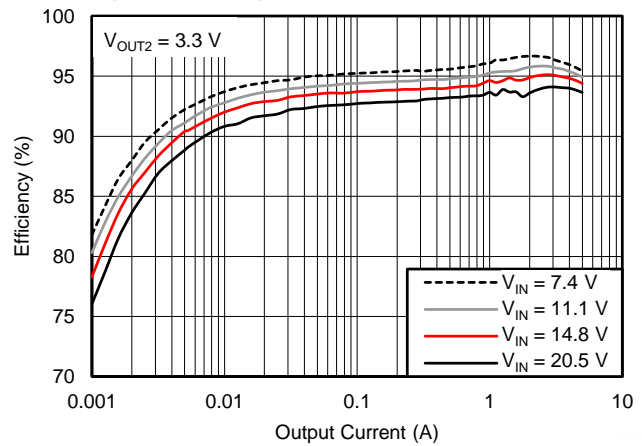

Figure 16. Efficiency vs. Output Current

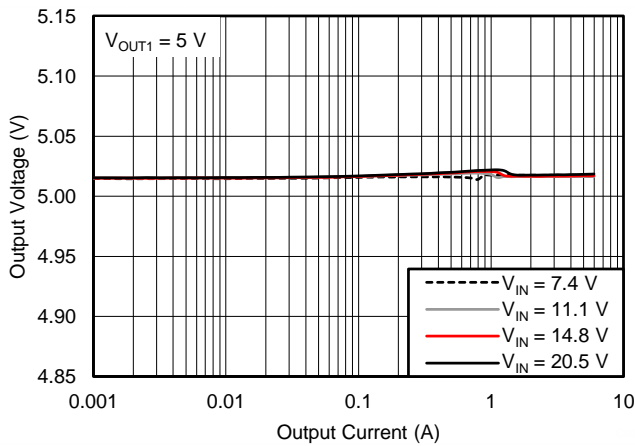

Figure 17. Load Regulation

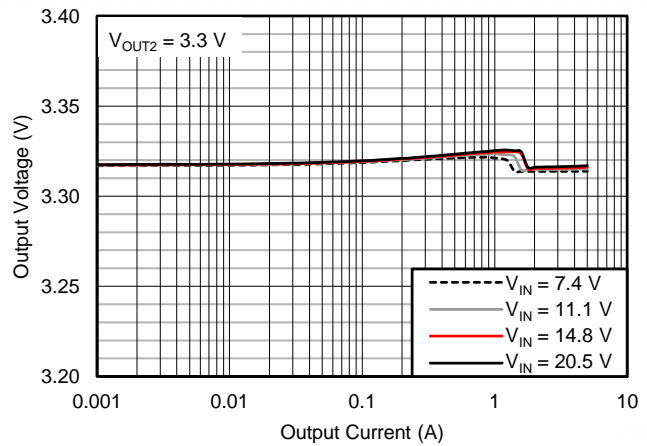

Figure 18. Load Regulation

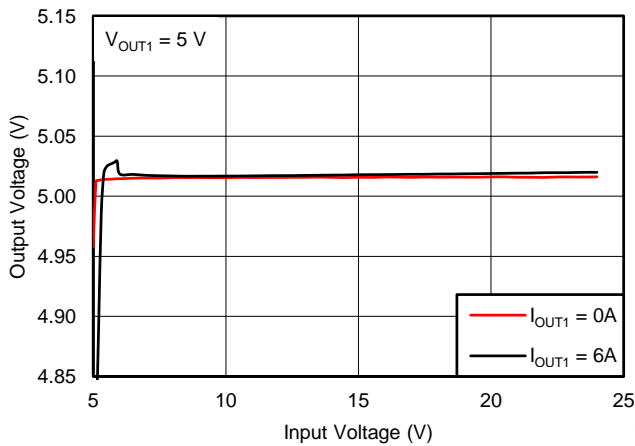

Figure 19. Line Regulation

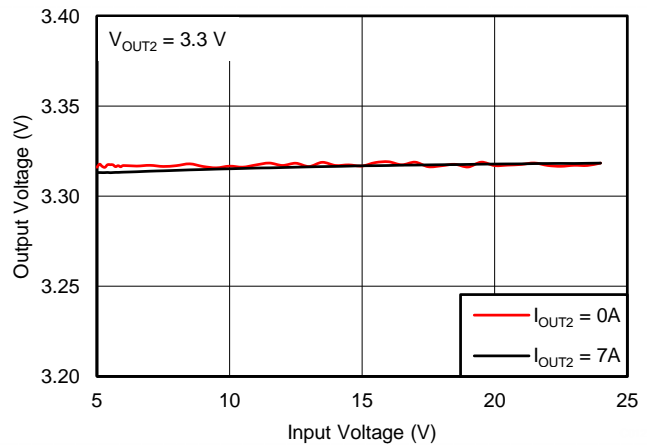

Figure 20. Line Regulation

TYPICAL CHARACTERISTICS (continued)

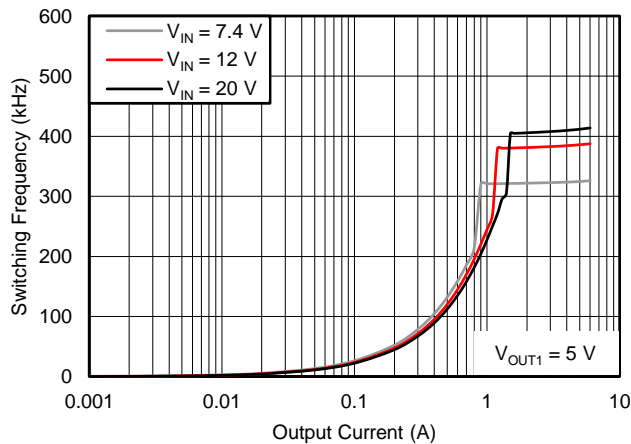

Figure 21. Switching Frequency vs. Output Current

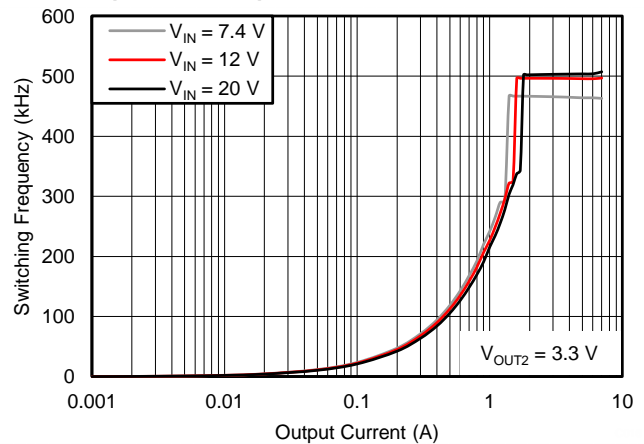

Figure 22. Switching Frequency vs. Output Current

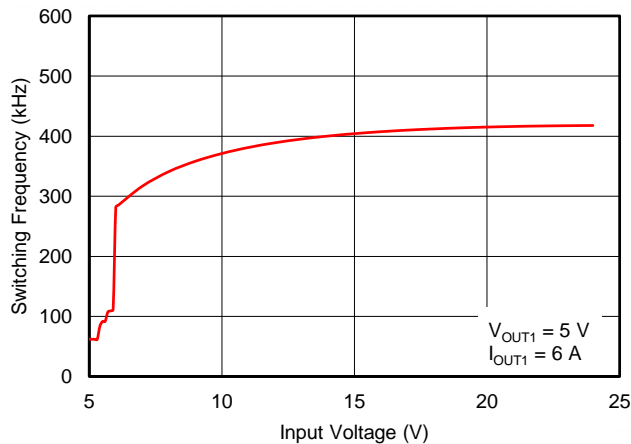

Figure 23. Switching Frequency vs. Input Voltage

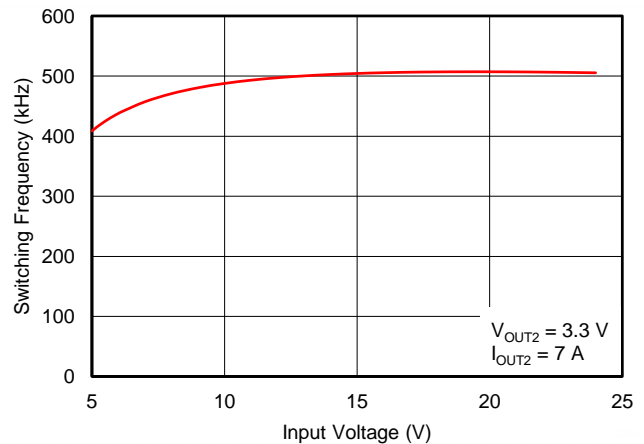

Figure 24. Switching Frequency vs. Input Voltage

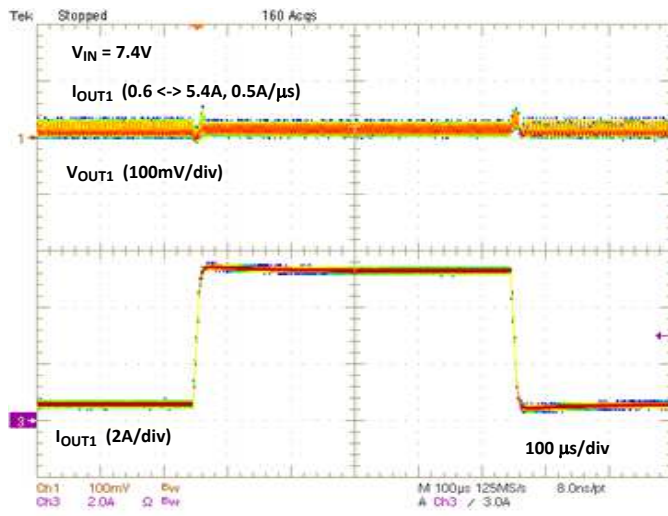

Figure 25. Load Transient

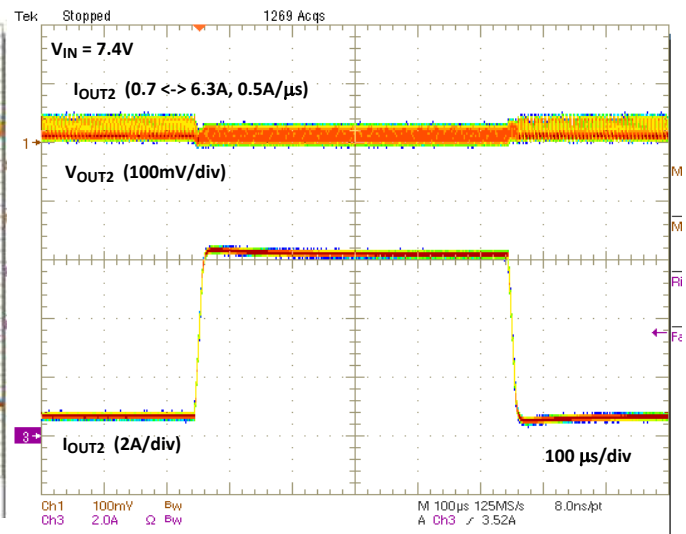

Figure 26. Load Transient

TYPICAL CHARACTERISTICS (continued)

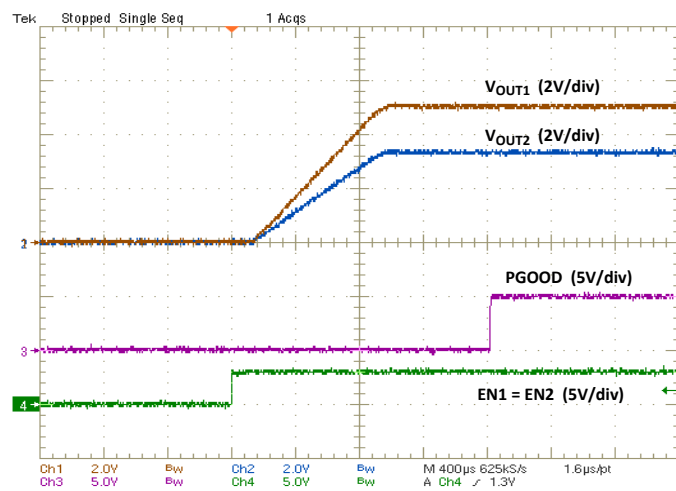

Figure 27. Start-Up

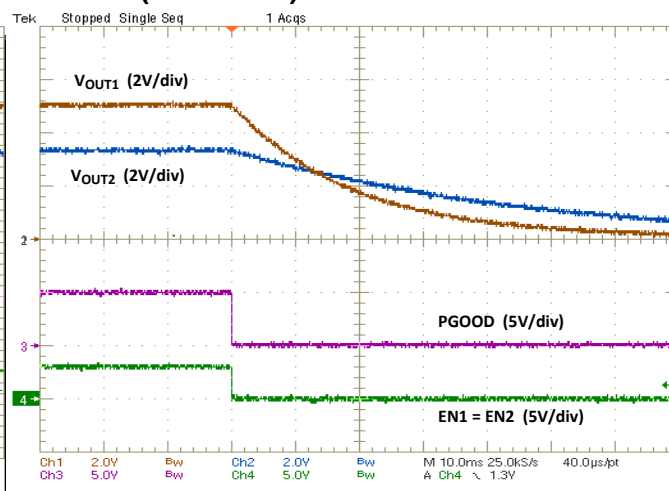

Figure 28. Output Discharge

PACKAGING INFORMATION

Orderable Device	Status (1)	Package Type	Package Drawing	Pins	Package Qty	Eco Plan (2)	Lead/Ball Finish	MSL Peak Temp (3)	Op Temp (°C)	Top-Side Markings (4)	Samples
TPS51285ARUKR	PREVIEW	WQFN	RUK	20	3000	Green (RoHS & no Sb/Br)	CU NIPDAUAG	Level-2-260C-1 YEAR	-40 to 85	1285A	
TPS51285ARUKT	PREVIEW	WQFN	RUK	20	250	Green (RoHS & no Sb/Br)	CU NIPDAUAG	Level-2-260C-1 YEAR	-40 to 85	1285A	
TPS51285BRUKR	PREVIEW	WQFN	RUK	20	3000	Green (RoHS & no Sb/Br)	CU NIPDAUAG	Level-2-260C-1 YEAR	-40 to 85	1285B	
TPS51285BRUKT	PREVIEW	WQFN	RUK	20	250	Green (RoHS & no Sb/Br)	CU NIPDAUAG	Level-2-260C-1 YEAR	-40 to 85	1285B	

(1) The marketing status values are defined as follows:

ACTIVE: Product device recommended for new designs.

LIFEBUY: TI has announced that the device will be discontinued, and a lifetime-buy period is in effect.

NRND: Not recommended for new designs. Device is in production to support existing customers, but TI does not recommend using this part in a new design.

PREVIEW: Device has been announced but is not in production. Samples may or may not be available.

OBSELETE: TI has discontinued the production of the device.

(2) Eco Plan - The planned eco-friendly classification: Pb-Free (RoHS), Pb-Free (RoHS Exempt), or Green (RoHS & no Sb/Br) - please check <http://www.ti.com/productcontent> for the latest availability information and additional product content details.

TBD: The Pb-Free/Green conversion plan has not been defined.

Pb-Free (RoHS): TI's terms "Lead-Free" or "Pb-Free" mean semiconductor products that are compatible with the current RoHS requirements for all 6 substances, including the requirement that lead not exceed 0.1% by weight in homogeneous materials. Where designed to be soldered at high temperatures, TI Pb-Free products are suitable for use in specified lead-free processes.

Pb-Free (RoHS Exempt): This component has a RoHS exemption for either 1) lead-based flip-chip solder bumps used between the die and package, or 2) lead-based die adhesive used between the die and leadframe. The component is otherwise considered Pb-Free (RoHS compatible) as defined above.

Green (RoHS & no Sb/Br): TI defines "Green" to mean Pb-Free (RoHS compatible), and free of Bromine (Br) and Antimony (Sb) based flame retardants (Br or Sb do not exceed 0.1% by weight in homogeneous material)

(3) MSL, Peak Temp. -- The Moisture Sensitivity Level rating according to the JEDEC industry standard classifications, and peak solder temperature.

(4) Multiple Top-Side Markings will be inside parentheses. Only one Top-Side Marking contained in parentheses and separated by a "~" will appear on a device. If a line is indented then it is a continuation of the previous line and the two combined represent the entire Top-Side Marking for that device.

Important Information and Disclaimer: The information provided on this page represents TI's knowledge and belief as of the date that it is provided. TI bases its knowledge and belief on information provided by third parties, and makes no representation or warranty as to the accuracy of such information. Efforts are underway to better integrate information from third parties. TI has taken and continues to take reasonable steps to provide representative and accurate information but may not have conducted destructive testing or chemical analysis on incoming materials and chemicals. TI and TI suppliers consider certain information to be proprietary, and thus CAS numbers and other limited information may not be available for release.

In no event shall TI's liability arising out of such information exceed the total purchase price of the TI part(s) at issue in this document sold by TI to Customer on an annual basis.

RUK (S-PWQFN-N20)

PLASTIC QUAD FLATPACK NO-LEAD

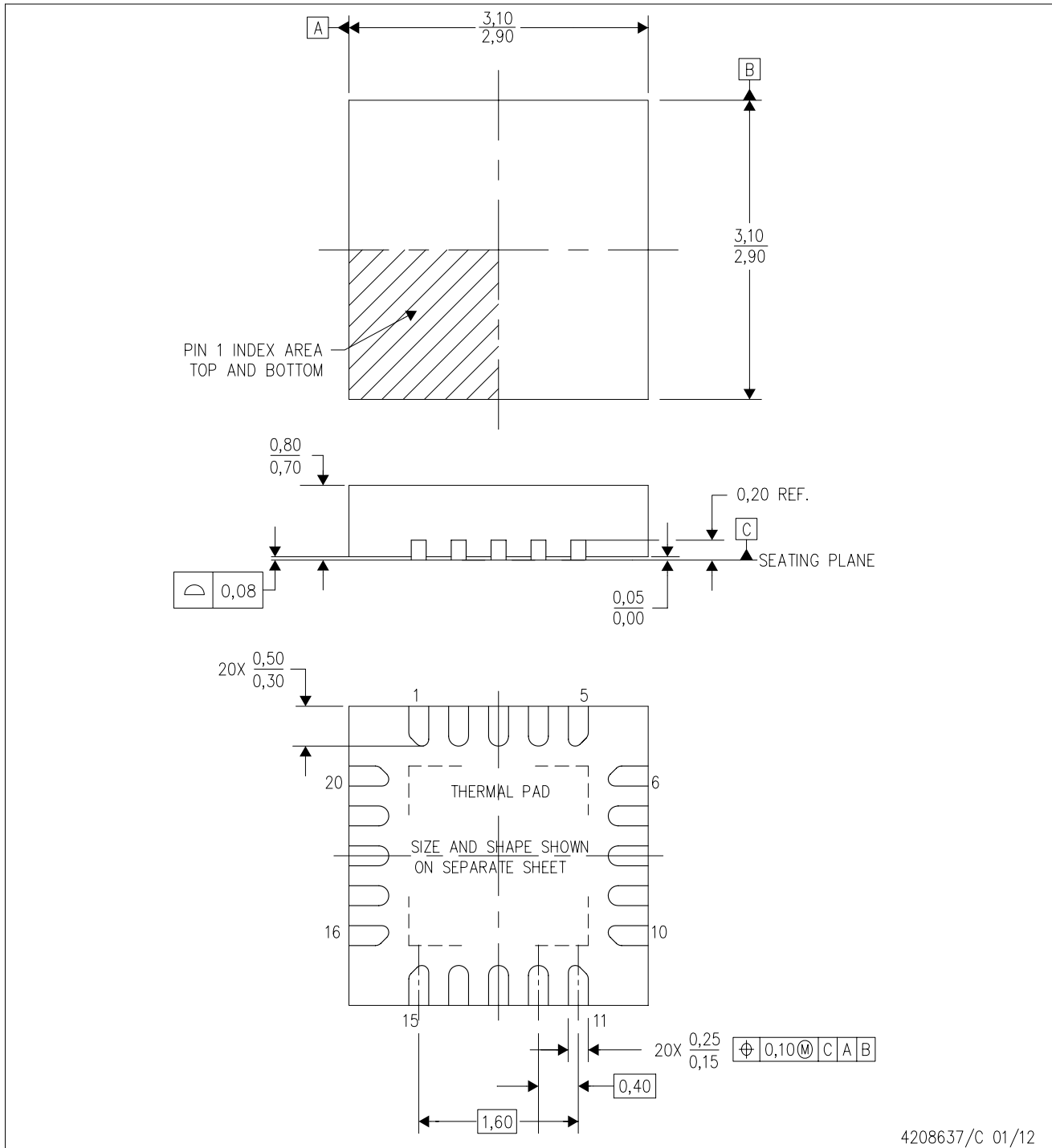

- NOTES:
- A. All linear dimensions are in millimeters. Dimensioning and tolerancing per ASME Y14.5M-1994.
 - B. This drawing is subject to change without notice.
 - C. Quad Flatpack, No-leads (QFN) package configuration.
 - D. The package thermal pad must be soldered to the board for thermal and mechanical performance.
 - E. See the additional figure in the Product Data Sheet for details regarding the exposed thermal pad features and dimensions.
 - F. Falls within JEDEC MO-220.

RUK (S-PWQFN-N20)

PLASTIC QUAD FLATPACK NO-LEAD

THERMAL INFORMATION

This package incorporates an exposed thermal pad that is designed to be attached directly to an external heatsink. The thermal pad must be soldered directly to the printed circuit board (PCB). After soldering, the PCB can be used as a heatsink. In addition, through the use of thermal vias, the thermal pad can be attached directly to the appropriate copper plane shown in the electrical schematic for the device, or alternatively, can be attached to a special heatsink structure designed into the PCB. This design optimizes the heat transfer from the integrated circuit (IC).

For information on the Quad Flatpack No-Lead (QFN) package and its advantages, refer to Application Report, QFN/SON PCB Attachment, Texas Instruments Literature No. SLUA271. This document is available at www.ti.com.

The exposed thermal pad dimensions for this package are shown in the following illustration.

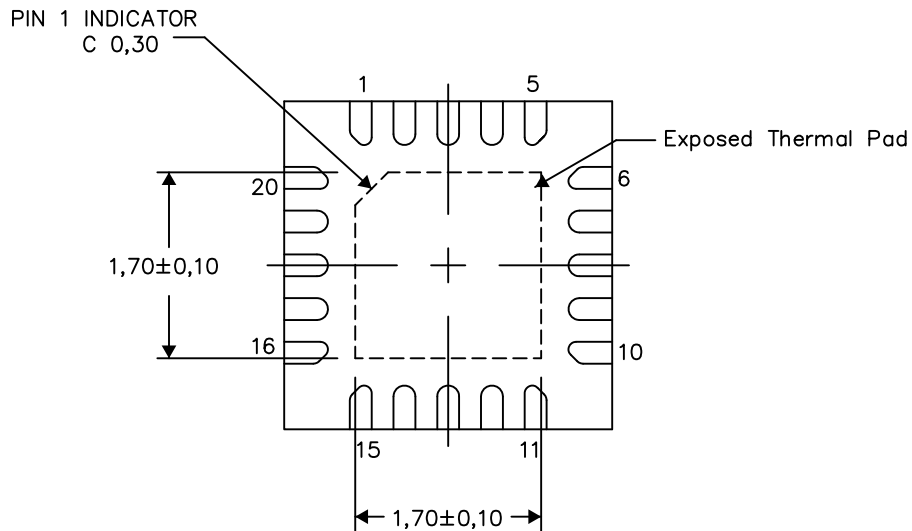

Bottom View

Exposed Thermal Pad Dimensions

4209762/E 12/12

NOTE: All linear dimensions are in millimeters

RUK (S-PWQFN-N20)

PLASTIC QUAD FLATPACK NO-LEAD

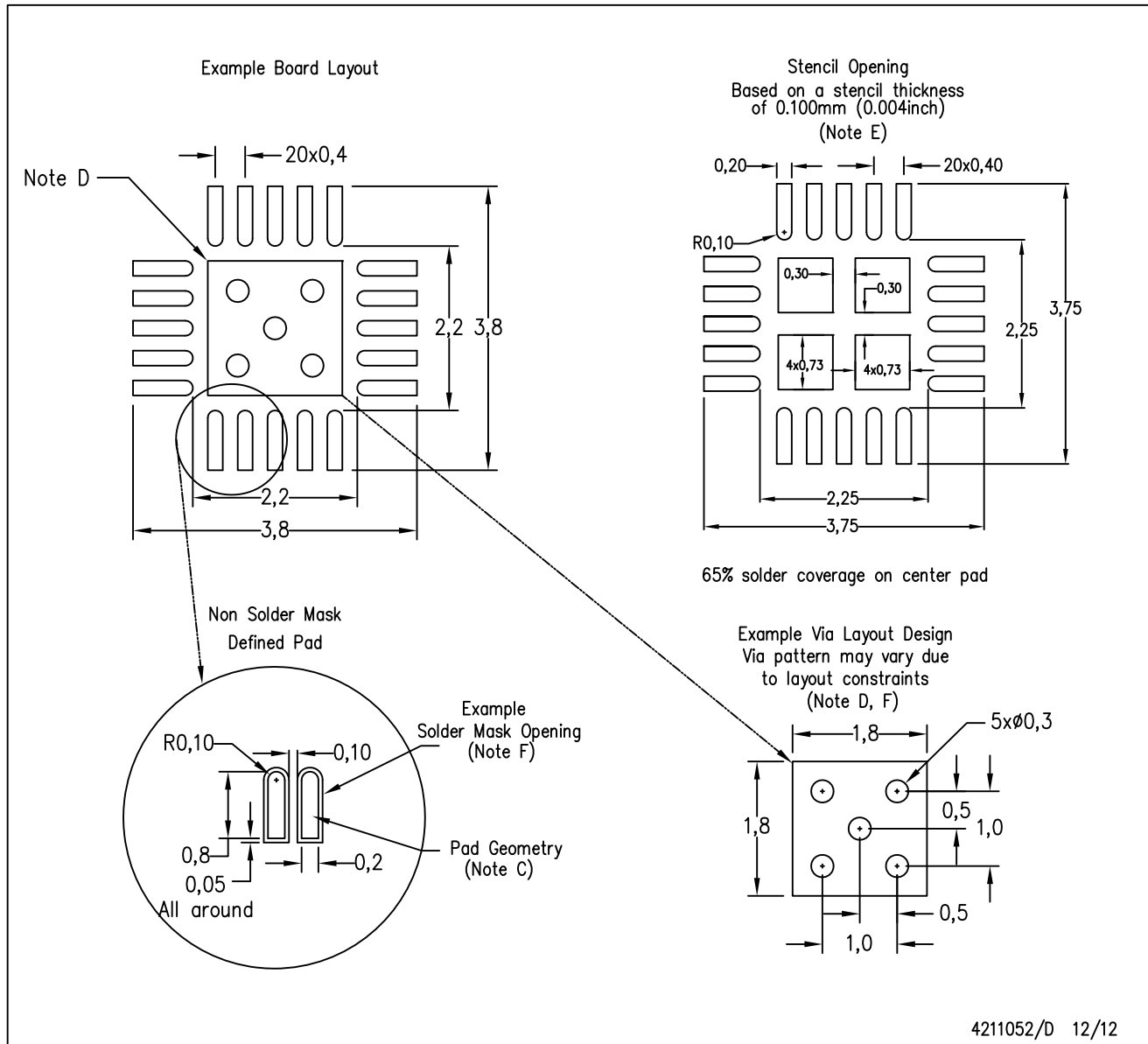

4211052/D 12/12

- NOTES:
- All linear dimensions are in millimeters.
 - This drawing is subject to change without notice.
 - Publication IPC-7351 is recommended for alternate designs.
 - This package is designed to be soldered to a thermal pad on the board. Refer to Application Note, Quad Flat-Pack Packages, Texas Instruments Literature No. SLUA271, and also the Product Data Sheets for specific thermal information, via requirements, and recommended board layout. These documents are available at www.ti.com <<http://www.ti.com>>.
 - Laser cutting apertures with trapezoidal walls and also rounding corners will offer better paste release. Customers should contact their board assembly site for stencil design recommendations. Refer to IPC 7525 for stencil design considerations.
 - Customers should contact their board fabrication site for minimum solder mask web tolerances between signal pads.

IMPORTANT NOTICE

Texas Instruments Incorporated and its subsidiaries (TI) reserve the right to make corrections, enhancements, improvements and other changes to its semiconductor products and services per JESD46, latest issue, and to discontinue any product or service per JESD48, latest issue. Buyers should obtain the latest relevant information before placing orders and should verify that such information is current and complete. All semiconductor products (also referred to herein as "components") are sold subject to TI's terms and conditions of sale supplied at the time of order acknowledgment.

TI warrants performance of its components to the specifications applicable at the time of sale, in accordance with the warranty in TI's terms and conditions of sale of semiconductor products. Testing and other quality control techniques are used to the extent TI deems necessary to support this warranty. Except where mandated by applicable law, testing of all parameters of each component is not necessarily performed.

TI assumes no liability for applications assistance or the design of Buyers' products. Buyers are responsible for their products and applications using TI components. To minimize the risks associated with Buyers' products and applications, Buyers should provide adequate design and operating safeguards.

TI does not warrant or represent that any license, either express or implied, is granted under any patent right, copyright, mask work right, or other intellectual property right relating to any combination, machine, or process in which TI components or services are used. Information published by TI regarding third-party products or services does not constitute a license to use such products or services or a warranty or endorsement thereof. Use of such information may require a license from a third party under the patents or other intellectual property of the third party, or a license from TI under the patents or other intellectual property of TI.

Reproduction of significant portions of TI information in TI data books or data sheets is permissible only if reproduction is without alteration and is accompanied by all associated warranties, conditions, limitations, and notices. TI is not responsible or liable for such altered documentation. Information of third parties may be subject to additional restrictions.

Resale of TI components or services with statements different from or beyond the parameters stated by TI for that component or service voids all express and any implied warranties for the associated TI component or service and is an unfair and deceptive business practice. TI is not responsible or liable for any such statements.

Buyer acknowledges and agrees that it is solely responsible for compliance with all legal, regulatory and safety-related requirements concerning its products, and any use of TI components in its applications, notwithstanding any applications-related information or support that may be provided by TI. Buyer represents and agrees that it has all the necessary expertise to create and implement safeguards which anticipate dangerous consequences of failures, monitor failures and their consequences, lessen the likelihood of failures that might cause harm and take appropriate remedial actions. Buyer will fully indemnify TI and its representatives against any damages arising out of the use of any TI components in safety-critical applications.

In some cases, TI components may be promoted specifically to facilitate safety-related applications. With such components, TI's goal is to help enable customers to design and create their own end-product solutions that meet applicable functional safety standards and requirements. Nonetheless, such components are subject to these terms.

No TI components are authorized for use in FDA Class III (or similar life-critical medical equipment) unless authorized officers of the parties have executed a special agreement specifically governing such use.

Only those TI components which TI has specifically designated as military grade or "enhanced plastic" are designed and intended for use in military/aerospace applications or environments. Buyer acknowledges and agrees that any military or aerospace use of TI components which have **not** been so designated is solely at the Buyer's risk, and that Buyer is solely responsible for compliance with all legal and regulatory requirements in connection with such use.

TI has specifically designated certain components as meeting ISO/TS16949 requirements, mainly for automotive use. In any case of use of non-designated products, TI will not be responsible for any failure to meet ISO/TS16949.

Products

Audio	www.ti.com/audio
Amplifiers	amplifier.ti.com
Data Converters	dataconverter.ti.com
DLP® Products	www.dlp.com
DSP	dsp.ti.com
Clocks and Timers	www.ti.com/clocks
Interface	interface.ti.com
Logic	logic.ti.com
Power Mgmt	power.ti.com
Microcontrollers	microcontroller.ti.com
RFID	www.ti-rfid.com
OMAP Applications Processors	www.ti.com/omap
Wireless Connectivity	www.ti.com/wirelessconnectivity

Applications

Automotive and Transportation	www.ti.com/automotive
Communications and Telecom	www.ti.com/communications
Computers and Peripherals	www.ti.com/computers
Consumer Electronics	www.ti.com/consumer-apps
Energy and Lighting	www.ti.com/energy
Industrial	www.ti.com/industrial
Medical	www.ti.com/medical
Security	www.ti.com/security
Space, Avionics and Defense	www.ti.com/space-avionics-defense
Video and Imaging	www.ti.com/video

TI E2E Community

e2e.ti.com